

Power Source Technology for the Future

Denyo

The BEST choice for your Engine-Driven Welder



CLICK our special website for more information on Denyo welder!!



 **Denyo Co., Ltd.**
<https://www.denyo.co.jp>

Copyright©2021 Denyo Co.,Ltd, All Rights Reserved.

I'M LOOKING FOR AN **ENGINE-DRIVEN WELDER**... DO YOU KNOW ANY GOOD BRANDS?

Dento
Looking for a good engine welder

Yoko
Well-informed about engine welders

OH, I KNOW OF ONE! **DENYO'S ENGINE-DRIVEN WELDER!**

OH, YES, I HAVE HEARD ABOUT DENYO'S ENGINE WELDERS. BUT THERE'S SOMETHING THAT I'M CURIOUS ABOUT.

Hmm...

WHAT IS IT?

DENYO'S ENGINE WELDERS ARE ALL 3000/3600RPM, RIGHT? WHY DON'T THEY MAKE ANY WITH 1500/1800RPM?

OH, THAT'S BECAUSE THERE ARE ADVANTAGES TO MAKING THEM 3000/3600RPM!

- IT'S SMALLER
- IT'S LIGHTER
- MOST IMPORTANTLY, IT'S CHEAPER!

BUT ISN'T THE 1500/1800RPM MORE DURABLE THAN THE 3000/3600RPM?

GIGGLE

NORMALLY, YES.

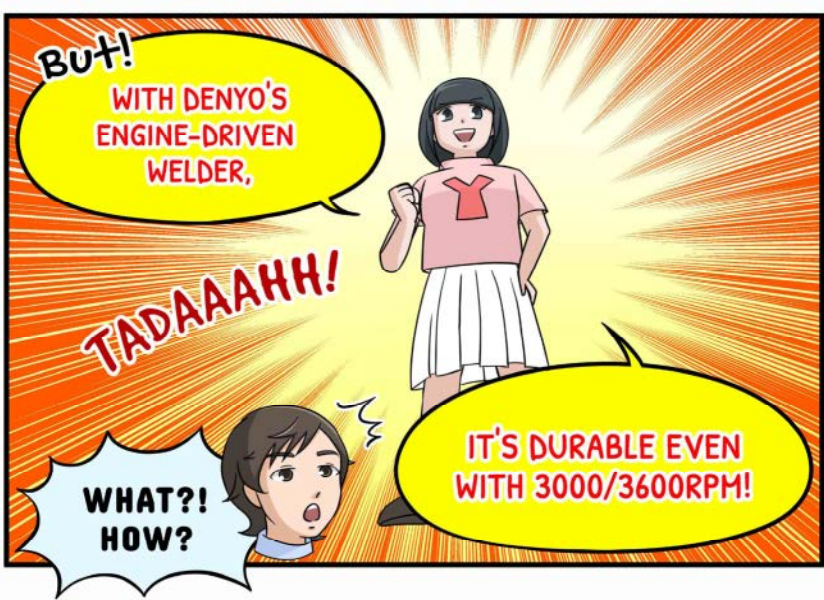

JAPANESE ENGINES

First!
Denyo's Engine-Driven Welder
uses a world-renowned
Japan-made engine!

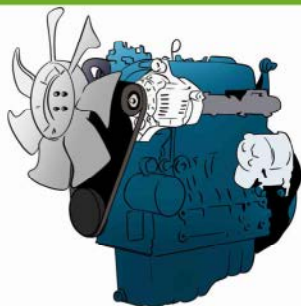

THE GENERATOR IS MANUFACTURED IN-HOUSE

The generator is made
by Denyo in-house.

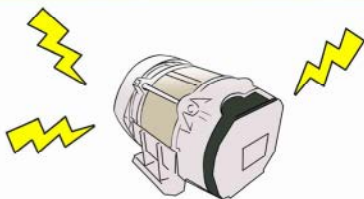
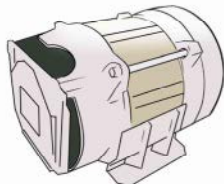

Denyo's generators are able
to generate electricity with
high efficiency.

HIGH-CLASS COOLING SYSTEM

When Denyo makes their engine welder
(generator), they meticulously calculate
the air flow in the room.

And that is why they have a
high-class cooling system.

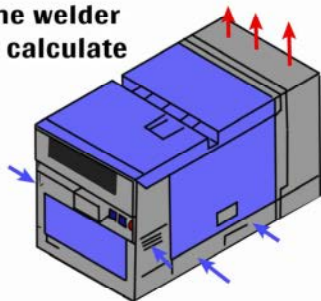

THE SLOWDOWN SYSTEM

All of Denyo's Engine Welders have a **Slowdown System**.

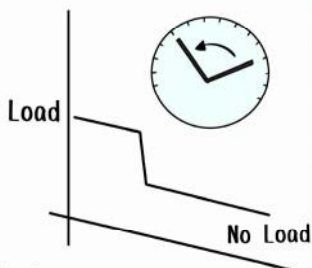

And because of that, the engine rotation is able to slow down while the engine is at no load.

SOME WELDERS EVEN COME WITH AN **IDLE STOP FUNCTION**.



WITH THIS ENGINE WELDER, THE ENGINE STOPS WHEN THERE IS NO LOAD!

How cool is that?

STURDY ENCLOSURE

They also make the enclosure really sturdy so that it can be carried around.

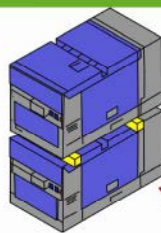

You can even double stack!

W-W-WAIT A MINUTE!

IT HAS SO MANY FEATURES! I CAN'T REMEMBER THEM ALL!

BUT...

I AM STARTING TO GET WHY DENYO'S 3000/3600RPM ENGINE-DRIVEN WELDERS CAN BE VERY DURABLE.

RIGHT? TO BE HONEST, THERE'S MORE TO IT.

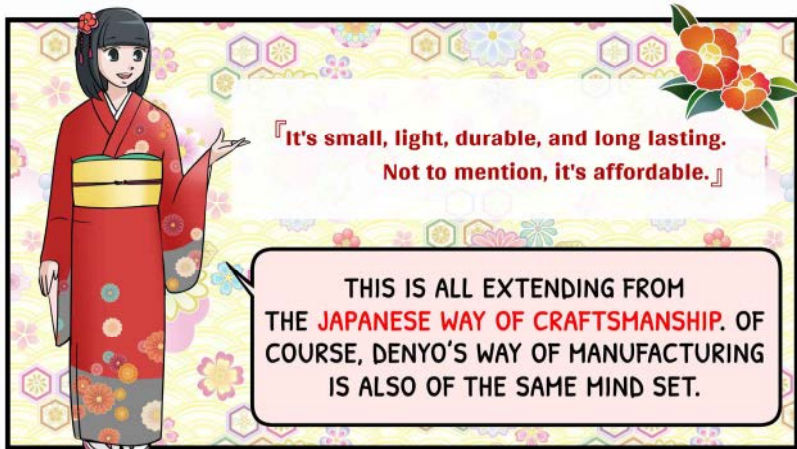

『It's small, light, durable, and long lasting. Not to mention, it's affordable.』

THIS IS ALL EXTENDING FROM THE **JAPANESE WAY OF CRAFTSMANSHIP**. OF COURSE, DENYO'S WAY OF MANUFACTURING IS ALSO OF THE SAME MIND SET.

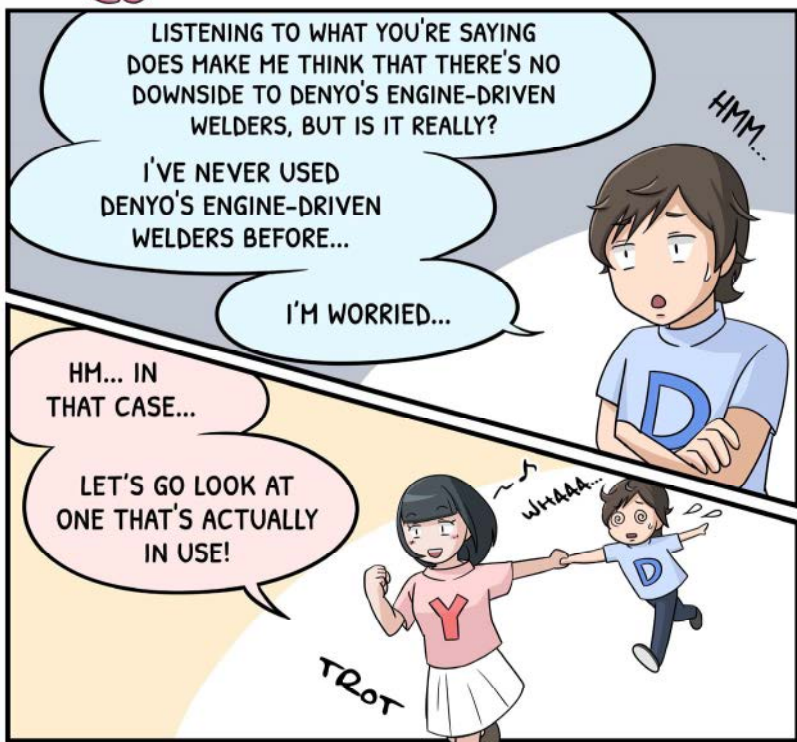

LISTENING TO WHAT YOU'RE SAYING DOES MAKE ME THINK THAT THERE'S NO DOWNSIDE TO DENYO'S ENGINE-DRIVEN WELDERS, BUT IS IT REALLY?

HMM...

I'VE NEVER USED DENYO'S ENGINE-DRIVEN WELDERS BEFORE...

I'M WORRIED...

HM... IN THAT CASE...

LET'S GO LOOK AT ONE THAT'S ACTUALLY IN USE!



WHOA! IT'S FREEZING OUT HERE! WHERE ARE WE?

THIS IS AROUND NORTHERN EURASIA

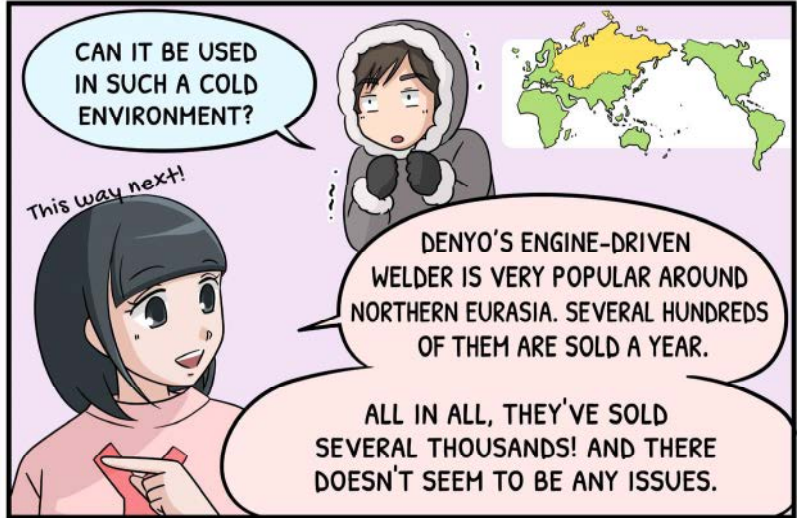

CAN IT BE USED IN SUCH A COLD ENVIRONMENT?



DENYO'S ENGINE-DRIVEN WELDER IS VERY POPULAR AROUND NORTHERN EURASIA. SEVERAL HUNDREDS OF THEM ARE SOLD A YEAR.

ALL IN ALL, THEY'VE SOLD SEVERAL THOUSANDS! AND THERE DOESN'T SEEM TO BE ANY ISSUES.

This way next!

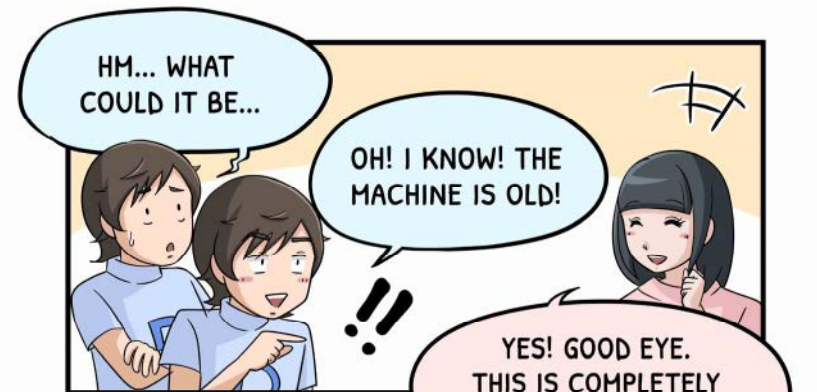
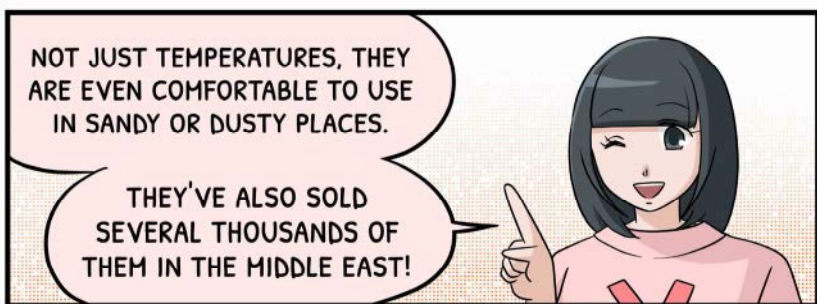
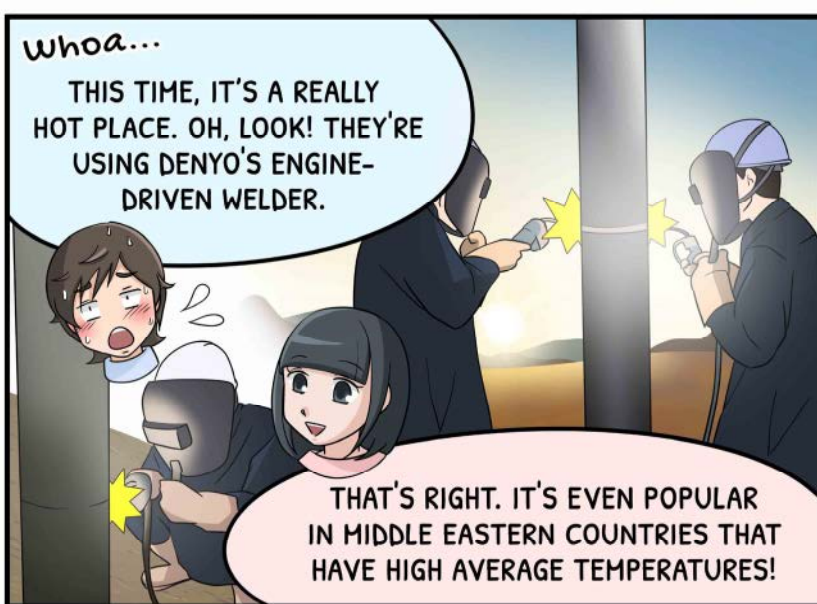

OF COURSE, IT NEEDS REGULAR CHECK-UPS AND I'M SURE IT HAS GONE THROUGH REPAIRS. BUT IT'S AMAZING HOW IT STILL WORKS EVEN AFTER THIRTY YEARS, DON'T YOU THINK?

THAT IS WHY, DENYO'S ENGINE-DRIVEN WELDERS ARE VALUABLE EVEN IF THEY'RE SECOND-HAND.

I THINK THIS IS GREAT PROOF OF HOW DURABLE DENYO'S ENGINE-DRIVEN WELDERS ARE.

COLD OR HOT, THEY ALL USE IT...

AND THEY'RE VALUABLE EVEN SECOND-HAND! I SEE! NOW I UNDERSTAND THAT DENYO'S ENGINE-DRIVEN WELDERS ARE STURDY!

Oh! DOES THIS MEAN THAT DENYO IS THE ONLY COMPANY THAT CAN MAKE A HIGH-QUALITY, DURABLE 3000/3600RPM ENGINE-DRIVEN WELDER?

THAT MAYBE A BIT OF AN OVERSTATEMENT, BUT IT CAN BE SAID THAT OUT OF ALL THE ENGINE-DRIVEN WELDERS OF THE WORLD, DENYO'S IS TOP CLASS.

I GUESS IT'S HARD TO FIND OTHER THIRTY-YEAR-OLD ENGINE-DRIVEN WELDERS STILL IN USE.

THERE'S MORE SECRETS TO UNCOVER IN DENYO. LET'S TAKE A LOOK AT THEIR FACTORY.

Whoa!
IT'S A VERY ORGANIZED FACTORY!

THEY'RE ALL WORKING SO HARD!

Oh! THIS IS THE PRODUCT INSPECTION AREA... WHOA, THAT LOOKS STRICT!

